

For sales and service contact your local dealer:



Trenchless Utility Equipment Inc.
2070 Queensway Drive,
P.O. Box 1338 Burlington, ON L7R 4L9
Ph: (905) 634-0669 Fax: (905) 634-6685
info@trenchlessutility.com

ASTECC

DD-3238



- 32,000 lb Thrust/Pullback force
- 3,800 ft-lbs. of rotary torque
- Dual Rack & Pinion Carriage Drive
- Single Multi-function joystick controls
- State-of-the-art rod loading capabilities!
- Hinged hoods allow easy access to all routine service points
- Enclosed mud pump

- New LCD multifunction operational screen at operators' station
- Two-speed rotating carriage
- 47 gpm onboard fluid pump

Astec DD-3238 Directional Drill

Weights & Dimensions

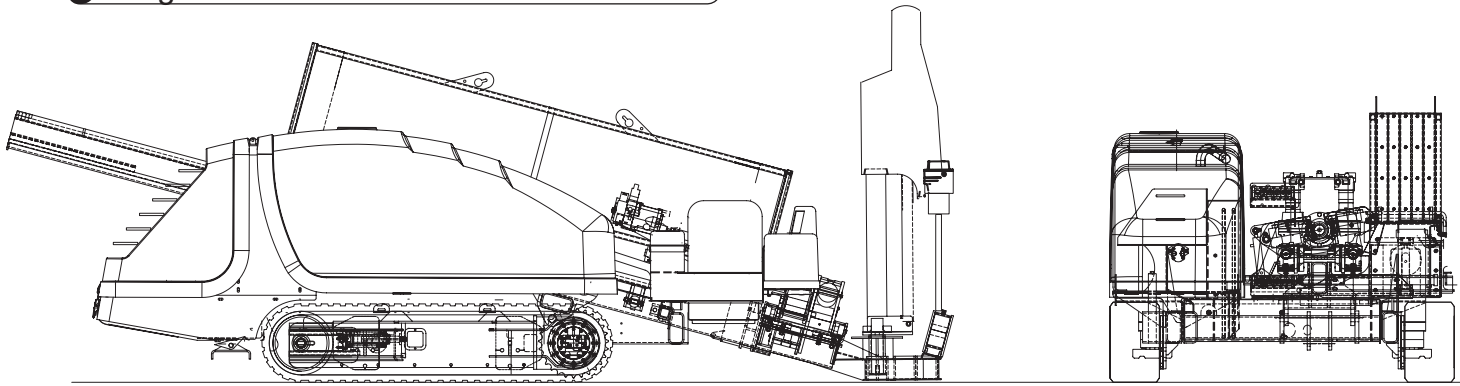

Transport Mode:

- Width: 88" (2.2 m)
- Length: 237-1/2" (6.0 m)
- Height: 98-1/2" (2.5 m)

Drilling Mode:

- Width: 115" (2.9 m)
- Length: 233-1/2" (5.9 m)
- Height: 87-1/2" (2.2 m)

- Ground Clearance: 12" (305 mm)
- Approximate Operating Weight: 17,280 lbs (7,838 kg)
(Includes 500 ft / 152m of Drill Pipe)

Engine

Engine	John Deere® 4045T Diesel
Rating	125 hp (93.2 kW)
Fuel capacity	67 U.S. gallons (254 L)
Other Features:	Quiet-Pak® Sound reduction system is standard.

Rotary Drive

Rotary system	Pinion and gear drive Infinitely variable speed & torque
Rotary	0 - 3,800 ft-lb. (5,152 Nm)
Max. rotary speed	225 rpm
Fluid course	1" (25 mm)
Other features	Digital LCD gauges for Rotation, Thrust, and Engine Functions, Rear mounted mud swivel, drive brake, rotating carriage, digital tachometer

Carriage Drive

Max. thrust/pullback	32,000 lb (14.5 Tonnes)
Carriage system	Two-speed floating carriage with two-pinion drive Dual Rack and Pinion
Carriage speed	Up to 120 ft/min (36.6 m/min)

Drilling Unit

Travel system	Self propelled on rubber tracks.
Flat Surface Speed	2.0- 3.25 mph (3.2 - 5.2 km/h)
Drill angle	15.5°
Wrench/clamp	Open top rotating vise grip type
Weight, drill unit	Approx. 17,280 lb (7,838 kg) with 50 pieces (500 ft. / 152 m) of pipe
Hold down system	Powered hydraulic augers in foot. Rear thrust stabilizers resist rearward movement of drill when pushing.

Drilling Fluid Pump

Onboard Mud Pump	Triplex pump
Output	0 - 47 GPM (178 L/min) @ 1500 psi (103 Bar), infinitely variable

Pipe Loader

State-of-the-art rod loader uses 10' (3.05m) drill stem. Total pipe capacity on drill is 500 ft (152.4m)

Drill pipe (optional)

Length	10 ft (3,048 mm)
Outside dia. (tube)	2-3/8 inch (60.5 mm)
Water course	1-7/8 inch (48 mm)
Tool joint O.D.	2-5/8 inch (66.5 mm)

Protective Equipment

Each drill comes with safety mats and electrical grounding rods. A Zap-Alert system is standard equipment. Emergency shut down switch at driller's console. The ES!LOK® exit-side lockout system is standard equipment.



Due to our continuing product improvement, specifications are subject to change without notice.
Headquarters: Astec Underground • 9600 Corporate Park Drive • Loudon, Tennessee 37774 USA
USA Toll Free: 800-527-6020 • Tel: 865-408-2100 • Fax: 865-458-8575
www.astecunderground.com

