

ASTECCTM

MCM-4000 Drilling Fluid Cleaning System



Photo shows optional equipment

Mix, clean and recycle drilling fluid in one compact, complete package!

- Large tanks—1,333 U.S. gallon (5045 L) screen (dirty) tank, 2,667 U.S. gallon (10095 L) clean fluid/mixing tank
- Reclaims bentonite to minimize use, which saves money
- Mix, clean and transfer material at the same time
- Six KVA of auxiliary power with 2 GFI duplex outlets
- Reduces volume of solids by control of moisture content for easier disposal
- Compact size for easier transportation, smaller jobsite foot print
- Processes up to 400 U.S. gallons per minute* (1514 L/min)
- On-board 90 kW Generator set to power screen shaker, pump motors and lights
- Two (2) tandem linear screen shakers, electric motor driven, are more efficient and require less maintenance than orbital type
- Mud jet agitation system
- Centrifugal circulating pump
- Five 5-inch desilter cones with individual shut off valves
- Optional electric-driven trash pump
- Fast, knowledgeable support from helpful local technicians
- Optional skid mount fits in standard ISO shipping container

*Based on 60-second mud returning with 30% solids by volume, cleaned to 3% solids at 25 micron size or less

MCM-4000 Drilling Fluid Cleaning System

Trailer mount

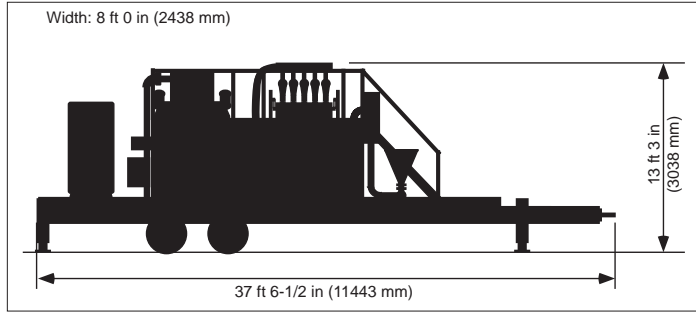

Electrical

Generator	480 volt 3 phase - 100 kW intermittent, 90 kW continuous
Auxiliary electrical	120/208 volt A.C. 6 kva 2 x duplex outlets with Ground Fault Interrupter 2 x 500 watt quartz work lights

Engine

Engine	Caterpillar® diesel 6 cylinder naturally aspirated
Rating	166 HP (123.8 kW) intermittent 150 HP (111.8 kW) continuous duty
Fuel capacity	42 U.S. gallons (160 L)

Tanks

Screen (dirty) tank	1,333 U.S. gallons (5045 L)
Clean fluid/mixing tank	2,667 U.S. gallons (10,095 L) With cleanout covers. Epoxy coated interiors.

Screens

Two linear motion shakers (46 x 55 inch, 1168 x 1397 mm) driven by electric motor, fold-down discharge chute for cuttings. Various screen mesh sizes available.

The rule of thumb is that the cleaning system should have 1.5 to 2 times the capacity of the mud pump on the job. The MCM-4000 suitable for use with drills whose mud pumps output is 200 to 260 gallons per minute.



Due to our continuing product improvement, specifications are subject to change without notice.
Headquarters: 9600 Corporate Park Drive • Loudon, Tennessee 37774 USA
USA Toll Free: 800-527-6020 • Tel: 865-408-2100 • Fax: 865-458-8575

Fluid Handling System

Rated Capacity	Up to 400 gpm (1514 L/min)
Circulating Pump	Centrifugal, electric driven, 5x6 30 hp (22.4 kW)
Desilting	Five inch cones (5 units) with manifolds and valves, fed by 3x4x20 HP (14.9 kW) centrifugal cone supply

Mud agitation	Eight jets
Bentonite mixer	Dry bentonite mix hopper and mixing system shears bentonite four times for maximum yield. Coated butterfly valve reduces clogging.

Protective Equipment

Work lights are standard. Electric motors are equipped with motor starters with overload relays. Machine has an emergency shut down switch. Supplied with electric grounding stake and cable. Safety railings around elevated work surfaces.

Options

Trash pump	Electric driven with circuit protection, with 100 ft (30.5 m) of 4-inch discharge hose with cam-lock fittings
Wash down system	110 gallon (415 L) poly tank, 1500 psi electric driven pressure pump, 100' (30.5 m) hose, hose reel

Trailers	Tandem dual axle tag trailer
----------	------------------------------

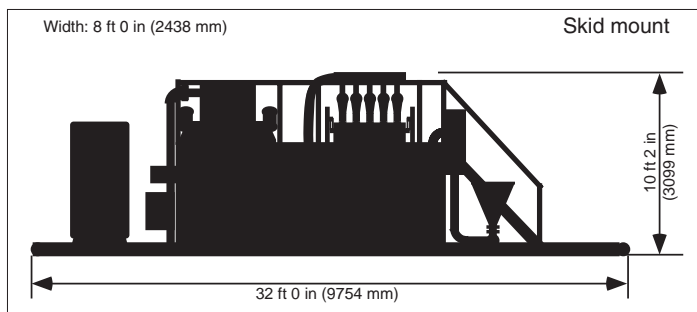

For sales and service, contact your local Astec Dealer:



Trenchless Utility Equipment Inc.
2070 Queensway Drive,
P.O. Box 1338 Burlington, ON L7R 4L9
Ph: (905) 634-0669 Fax: (905) 634-6685
info@trenchlessutility.com